



Fitzpatrick S.A.L.

PERFORMANCE METAL DOORSETS

QUALITY | RELIABILITY | SAFETY





Sectional doors ISD01

Installation requirements:

Opening height – from 2000 to 8000 mm.
Opening width – from 1700 to 8000 mm
Room depth – door leaf height +500 mm.
Minimum lintel height – 150 mm.
Minimum side space – 120 mm.

Fitzpatrick industrial sectional doors are an ideal business solution. Robust guides construction is designed to lift large door leaves which can withstand high intensity use. The torsion spring mechanism is designed for 25 000 of open/close cycles. Compared to other types of doors, Fitzpatrick industrial sectional doors are made from sandwich panels, steel-polyurethane-steel, which ensure high thermal insulation and maximum safety of the premises.

Stucco, RAL 9007, standard glazing



Sectional doors ISD02

Installation requirements:

Opening width — from 2000 to 6000 mm.
Opening height — from 2000 to 8000 mm.
Minimum lintel height — 150 mm
Minimum side space — 120 mm.
Room depth — door leaf height + 500mm.

Industrial sectional doors ISD02 series allow insertion of panoramic panels to the door leaf. Glazed panels are made of impact-resistant polycarbonate. ISD02 sectional doors can be produced in full glazing as well as in any combination with standard sandwich panels. Door glazing ensure maximum visibility of the inner and outer space, which contributes to a better operation in busy areas.

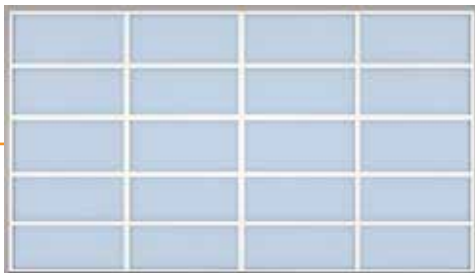

Doors with standard glazing



Fully glazed doors with width up to 3000 mm



Doors with standard glazing and pass door



Fully glazed doors with width from 3000 mm to 6000 mm

GLAZED DOORS WITH ALUMINUM GRILLE

Glazed division dimensions:
Height – from 370 to 650 mm
Width – up to 600 mm

For doors with vertical lifts and width from 4500 to 6000 mm, the width of glazed division without partition can be up to 900 mm. Standard glazed doors can be produced with pass doors with width from 600 to 1500 mm and height from 1100 to 2500 mm.

PANORAMIC PANEL DOORS

Full glazed panels dimensions:
Height – from 370 to 650 mm
Width – up to 3000 mm

Fully glazed panels provide maximum lighting of inner spaces. Pass doors can not be installed on fully glazed sectional doors.

PANORAMIC DOORS

PANORAMIC DOOR GLAZING TYPES

IS-Line, Stucco, RAL 9007, combined panoramic door



Partially glazed door

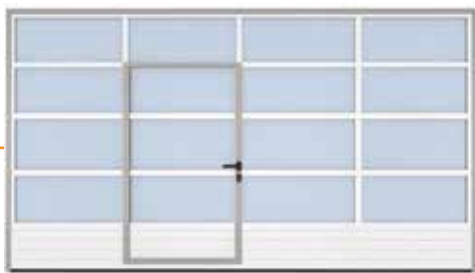

Partially glazed door with pass door

COMBINED PANORAMIC DOORS

Dimensions of glazed divisions:
Height – from 370 to 650 mm
Width – up to 600 mm

For vertical lift and door leaf width from 4500 to 6000 mm, the width of the glazed division without partition can be up to 900 mm. Pass doors with width from 600 to 1500 and height from 1100 to 2500 mm, can be installed on doors with standard glazing.



Panoramic panel with glazing bead and single-chamber window. Plexiglas or impact-resistant polycarbonate.



Panoramic panel with glazing bead and single-layer glaze. Plexiglas or impact-resistant

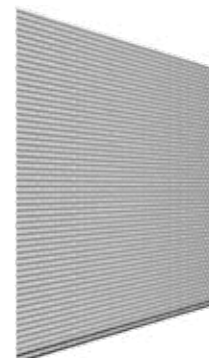

Panoramic panel with glazing bead and aluminum grille.

TECHNICAL SPECIFICATIONS

Wind load	Class 2 (EN12424:2000)
Water resistance	Class 3 (EN12425:2000)
Lift force	up to 40 kg
Door leaf weight	17 kg/m ²



PASS DOORS



Industrial sectional doors ISD series can be supplied with pass doors to ensure an additional entrance to the building without having to open the entire door. Double sealing system provides the door with great thermal insulation properties, retaining warmth in winter and cold in summer.

The pass door is equipped with a built-in closer, open pass door sensors and retainer. Standard frame color is silver.

V4 SERIES – HIGH STEP

Dimensions:

Standard width – 900 mm

Standard height – 1800/1900 mm

(depends on the height of panels)

Step height – 75 mm (without sealing)

Minimum distance from the pass door to the edge of door leaf – 400 mm

IS-Line, Stucco, RAL 5005, V5 low step



V5 SERIES – LOW STEP

Dimensions:
Standard width – 900 mm
Standard height – 1800/1900 mm
(depends on the height of panels)
Step height – 25 mm (without sealing)
Minimum distance from the pass door to the edge
of door leaf – 400 mm

SIDE ENTRANCE DOORS

Side entrance doors can be installed in the openings
with sufficient width. These doors can be used
independently from the sectional doors,
while retaining the same design and thermal insulation
properties.

DESIGN

TYPES OF PANELS

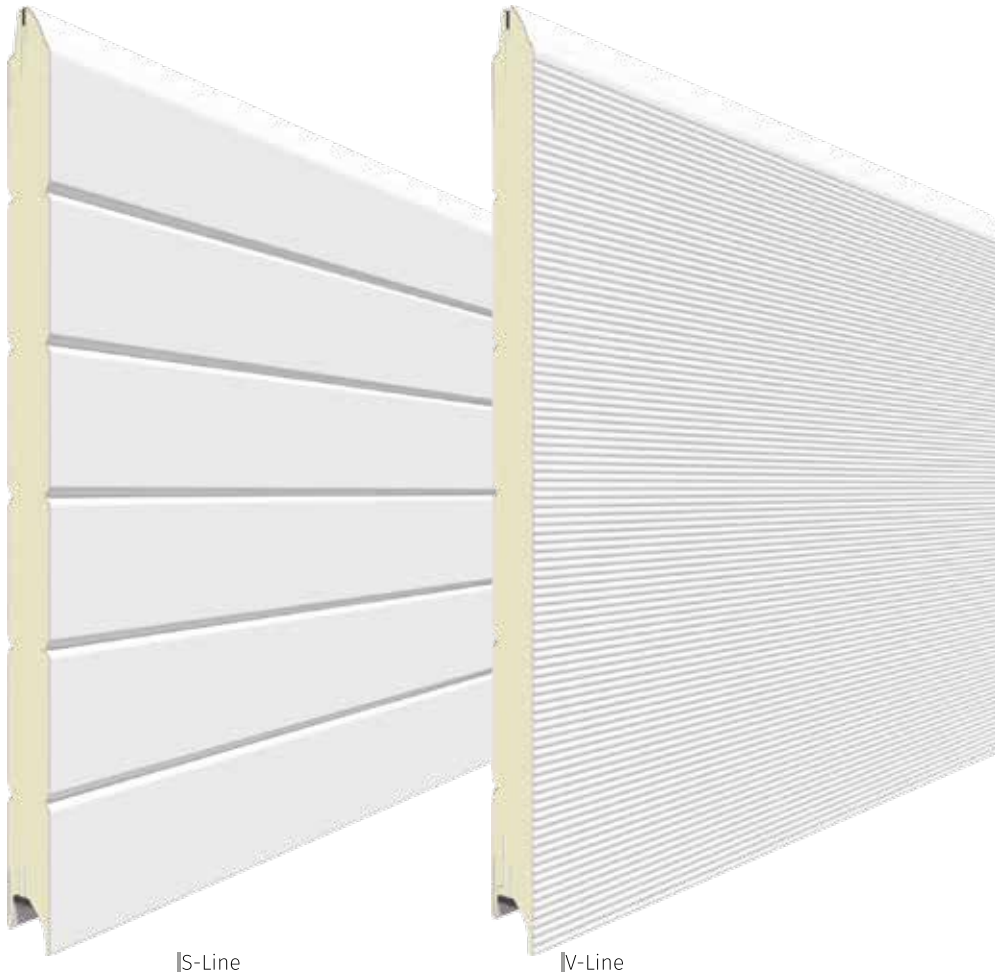

RAL COLOURS



|9010



|8014



|5005



|6005



|9006



|3000



|7016



|9005



|9007

SURFACE TYPE

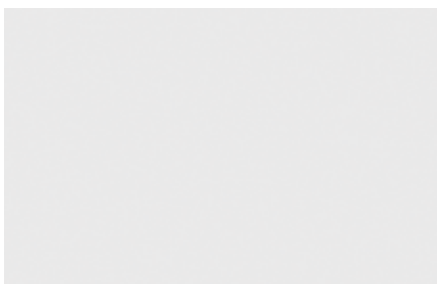

|Smooth

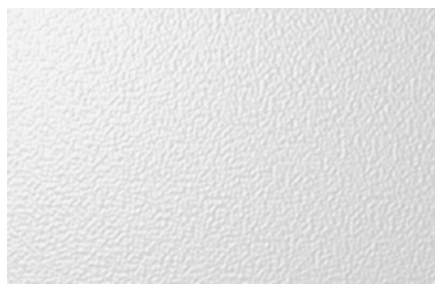

|Stucco

Panels can be painted in any colour from the International RAL Colour Chart. Colour swatches printed on this page may not accurately display the original colours. Please use the original RAL Colours Chart.

ACCESSORIES

WINDOWS

Windows can be integrated in sectional doors ISD01 series, which thanks to the special design, seal tightly to the door leaf and protect it from freezing and heat loss.



Black



Silver gray

Dimensions 638 × 338 mm



Dimensions 588 × 181 mm



Diameter 360 mm



Dimensions 452 × 322 mm

DEAD BOLT LOCK AND HANDLES

The dead bolt lock is made of stainless steel which increases its reliability. Ergonomically designed handles allows you to open the door manually, and also acting as a decorative element.



Handle for sectional doors ISD01 series



Handle for sectional doors ISD02 series



Lock for sectional doors ISD01 series

AUTOMATION ACCESSORIES

Remote controls, photocells, external receivers, keyboards and other automation accessories, allow a convenient and a safe door operation.

All control devices are optimized to connect with Fitzpatrick automation systems, but they can also be combined with devices from other manufacturers.

Remote controls are easy to program, within a few key presses, which saves time and provides a safe and easy operation of all automation systems.



External release system with key for residential door



Remote controls



Signal LED lamp



Photocells

OPERATORS FOR INDUSTRIAL SECTIONAL DOORS



Shaft-20 – for door leaves with area max. 12 m²



Shaft-30/60 – for door leaves with area max. 12 m²/28 m²



Shaft-50 – for door leaves with area max. 25 m²



Shaft-120 – for door leaves with area max. 40 m²

Thanks to the ceiling operators, the industrial sectional doors open and close at the touch of a button on the remote control. Operators are also equipped with built-in lighting, which turns on automatically when the motor is activated.

Model	Shaft 20	Shaft 30IP65	Shaft 50	Shaft 60IP65	Shaft 120
Power supply (V/Hz)	230/50 single phase			400 3-phases	
Maximum power consumption (W)	300	300	370	350	700
Torque (Nm)	20	30	50	60	120
Shaft speed (RPM)	25	32	24	32	22
Maximum door area (m ²)	12	18	25	28	40
Intensity (%)	30	50	50	60	65
Temperature range (°C)	from -20 to +55		from -20 to +50	from -20 to +55	
Protection class	IP20	IP65	IP54	IP65	IP44

INDUSTRIAL SECTIONAL DOOR CONSTRUCTION

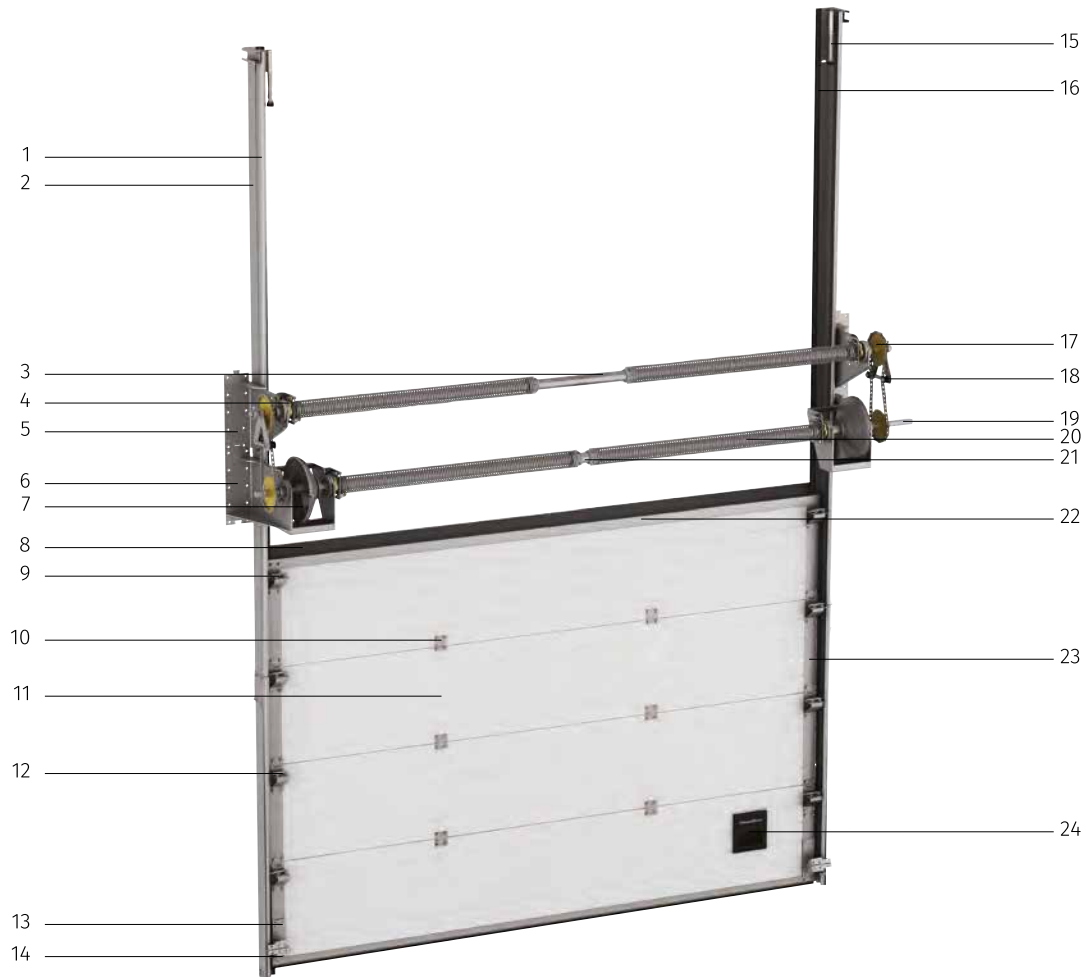

- | | |
|---|---|
| 1. Vertical track | 13. Cable break safety device |
| 2. Vertical angle | 14. Aluminum bottom profile |
| 3. Octagonal shaft | 15. Spring bumper |
| 4. Spring break safety device | 16. Side seal |
| 5. Support bracket for octagonal shaft | 17. Sprocket for additional shaft |
| 6. Support bracket for octagonal shaft, inner drum assembly | 18. Chain tensioner for the double shaft mechanism |
| 7. Cable drum | 19. End adapter |
| 8. Top seal | 20. Balancing spring mechanism (torsion spring) |
| 9. Upper hinge with roller carrier | 21. Spring end movable part |
| 10. Intermediate hinge | 22. Aluminum top profile |
| 11. Sandwich-panel | 23. Side cap for door panel with bearings for fastening |
| 12. Side hinge with roller carrier | 24. Handle for industrial sectional doors |

LIFT TYPES

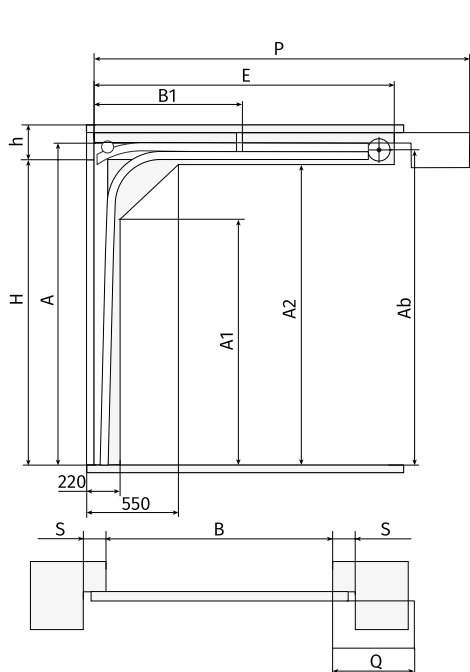

Low lift, cable drum behind

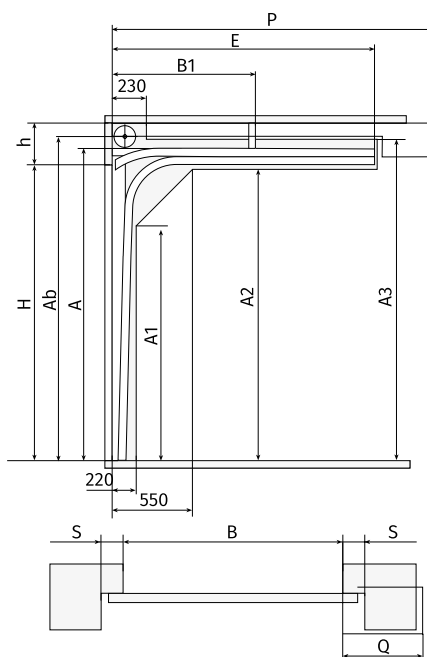

Low lift, cable drum in front

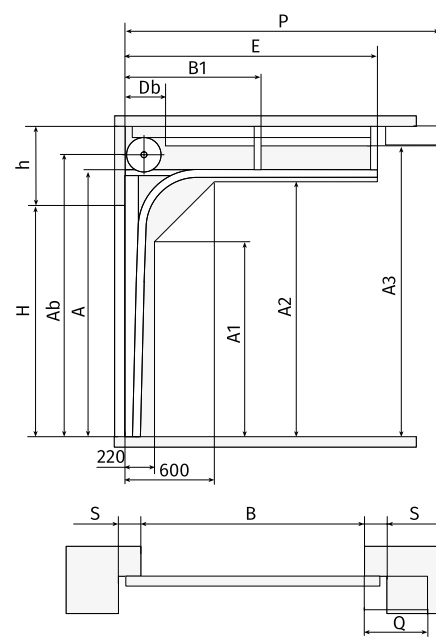

Standard lift

Model	Low lift, cable drum behind	Low lift, cable drum in front	Standard lift
Opening height (H, mm)	H	H	H
Lintel height (h, mm)	without operator 150, with operator 200	$h \geq 230$	R381 $h \geq 410$, R305 $h \geq 350$
Opening width (B, mm)	B	B	B
Height of the vertical tracks (A, mm)	$H + 110$	$H + 110$	R381 $A = H + 235$, R305 $A = H + 165$
The height of the shaft and cable drum (Ab, mm)	$H + 55$	$A + 86$	$A + 86$, (if $H > 5500$, then $A + 156$)
The working space of the door between the vertical tracks (A1, mm)	$H - 360$	$H - 470$	$H - 500$
The height of the upper working space of the door (A2, mm)	$H - 10$	$A - 120$	$A - 110$
Upper working area of the door with operator (A3, mm)	$H + 180$	$A + 70$	$A + 150$
Length of the horizontal tracks (E, mm)	$H + 400$	$H + 300$	$H + 270$
Location of fixing points of the tracks the ceiling (B1, mm)	$E/2$	$E/2$	$E/2$
Working area of the torsion mechanism (Db, mm)	depends on the opening size and door leaf weight	depends on the opening size and door leaf weight	depends on the opening size and door leaf weight
Minimum side space (S, mm)	120	120	120
Location of the operator on the shaft (Q, mm)	360	240	240
Location of the operator on the ceiling (P, mm)	$H + 1185$	$H + 1185$	$H + 1060$

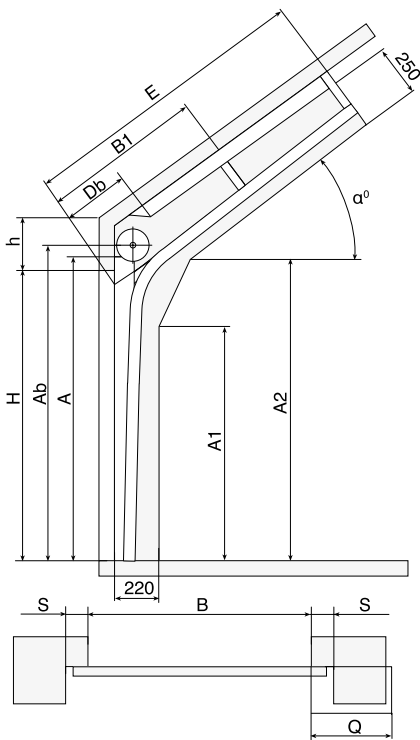

Standard inclined lift

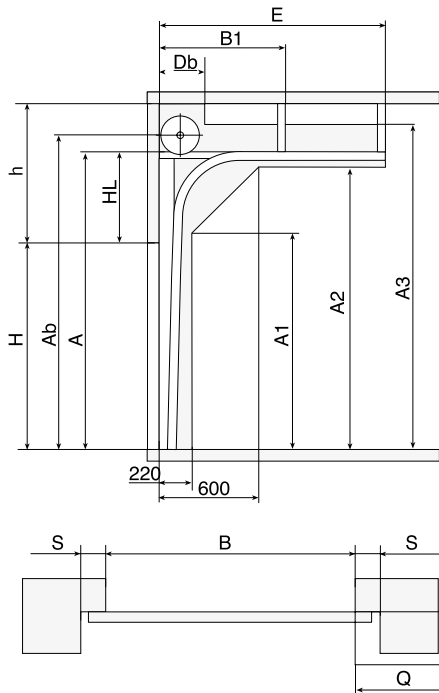

High lift

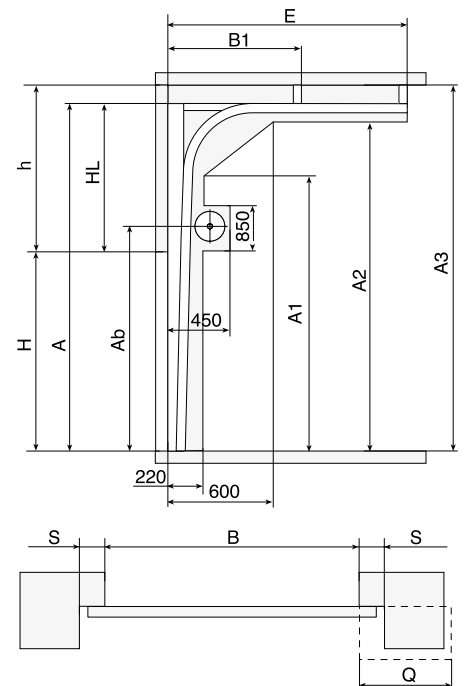

High lift, low level cable drum

Model	Standard inclined lift	High lift	High lift, low level cable drum
Opening height (H, mm)	H	H	H
Lintel height (h, mm)	500 up to 1500 (depends on the α°)	$h > 600$	$h > 1600$
Opening width (B, mm)	B	B	B
Height of the vertical tracks (A, mm)	$H + (250 \text{ až } 990)$	$H + HL$	$H + HL$
The height of the shaft and cable drum (Ab, mm)	$A + 86$	$A + 86$	$\geq H + 680$
The working space of the door between the vertical tracks (A1, mm)	$H - 270$	$H - 500$	$H - 500$
The height of the upper working space of the door (A2, mm)	$H - 110$	$A - 110$	$A - 110$
Upper working area of the door with operator (A3, mm)		$A + 120$	$A + 120$
Length of the horizontal tracks (E, mm)	$H + (250 + 1000)$	$H - HL + 350$	$H - HL + 350$
Location of fixing points of the tracks the ceiling (B1, mm)	$E/2$	$E/2$	$E/2$
Working area of the torsion mechanism (Db, mm)	depends on the opening size and door leaf weight	depends on the opening size and door leaf weight	depends on the opening size and door leaf weight
Minimum side space (S, mm)	120	120	500
Location of the operator on the shaft (Q, mm)		240	≥ 650
Location of the operator on the ceiling (P, mm)	240		
Angle of inclination of the tracks relative to the horizontal (α°)	≤ 360		
Working area of the torsion mechanism (Db, mm)		$\leq h - 250$	$1330 \leq HL \leq h - 150$

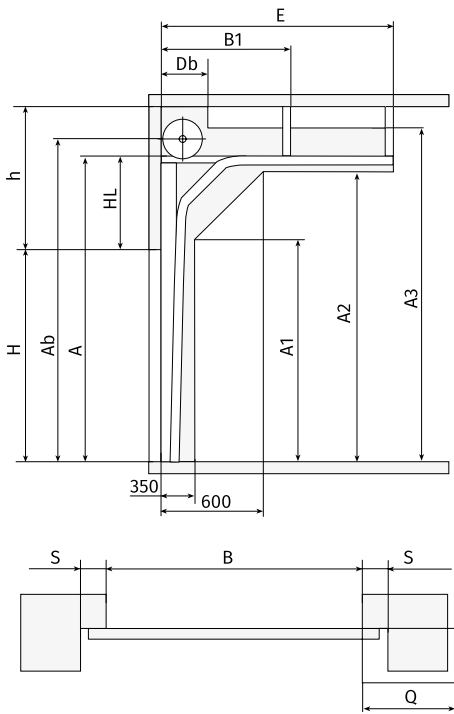

High lift with double bend

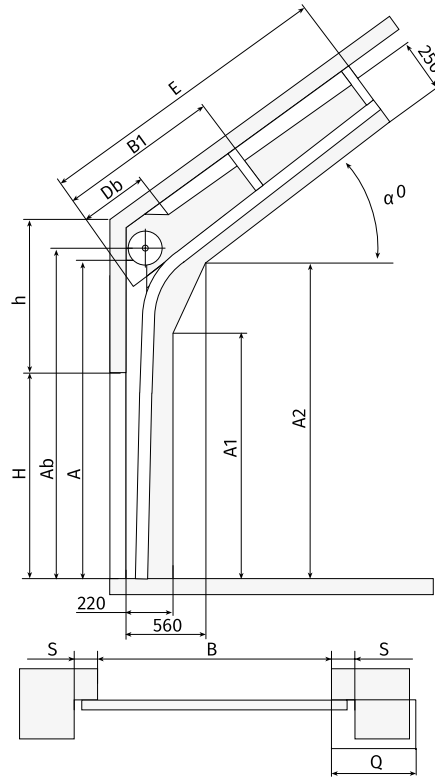

High inclined lift

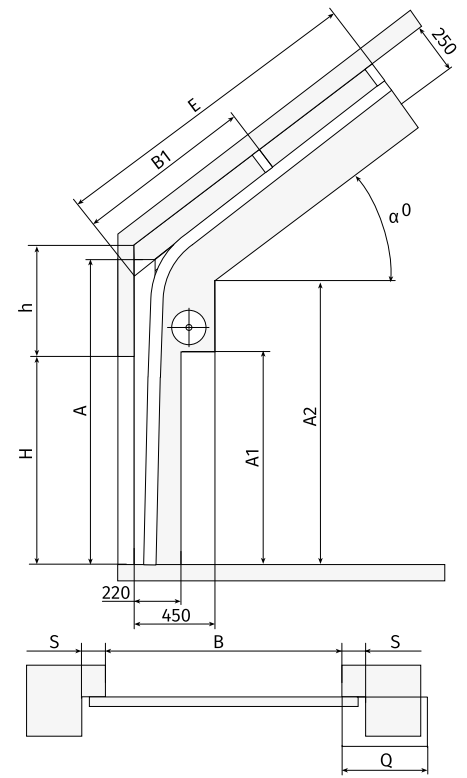

High inclined lift, low level cable drum

Model	High lift with double bend	High inclined lift	High inclined lift, low level cable drum
Opening height (H, mm)	H	H	H
Lintel height (h, mm)	> 600	HL + (20 + 1260)	h > 1600
Opening width (B, mm)	B	B	B
Height of the vertical tracks (A, mm)	H + HL	H + HL + (250 až 990)	H + 235
The height of the shaft and cable drum (Ab, mm)	A + 86	A + 86	≥ H + 680
The working space of the door between the vertical tracks (A1, mm)	A - 500	H - 270	A - 500
The height of the upper working space of the door (A2, mm)	A - 110	H - 110	A - 110
Upper working area of the door with operator (A3, mm)	A + 120		
Length of the horizontal tracks (E, mm)	H - HL + 350	H - HL + (250 + 1000)	H - h + 500
Location of fixing points of the tracks the ceiling (B1, mm)	E/2	E/2	E/2
Working area of the torsion mechanism (Db, mm)	depends on the opening size and door leaf weight	depends on the opening size and door leaf weight	depends on the opening size and door leaf weight
Minimum side space (S, mm)	120	120	500
Location of the operator on the shaft (Q, mm)	240	240	≥ 650
Angle of inclination of the tracks relative to the horizontal (α°)		≤ 65	≤ 65
Distance between the horizontal tracks and the opening (HL, mm)	> 65		≥ 1330

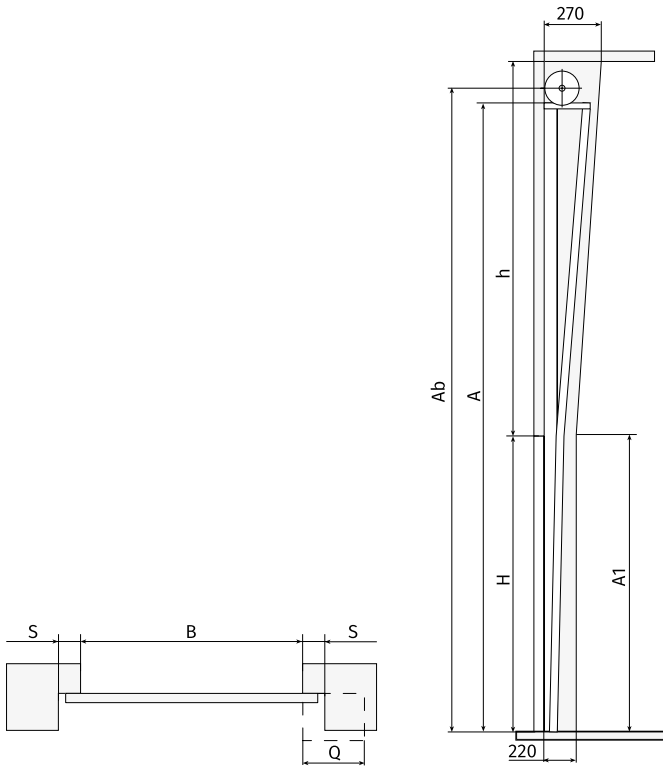

Vertical lift

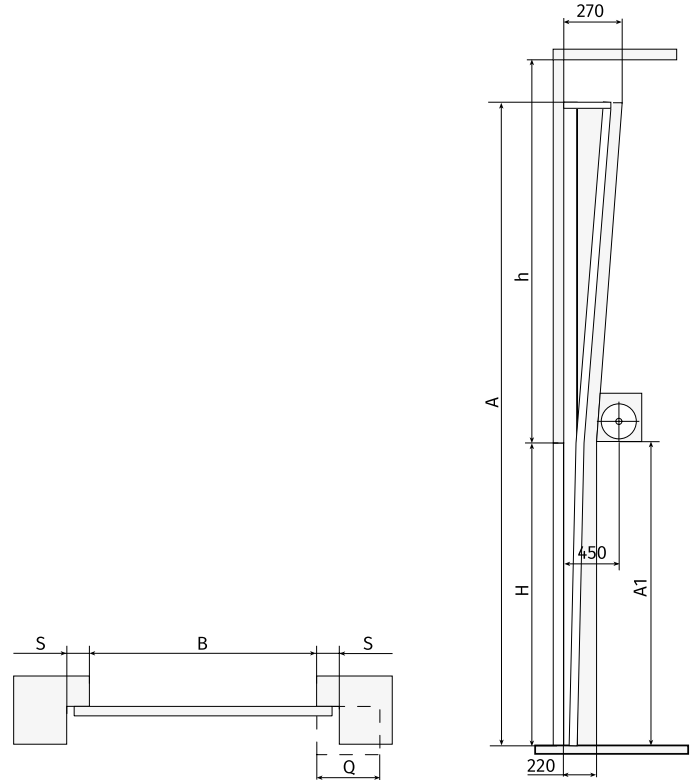

Vertical lift, low level cable drum

Model	Vertical lift	Vertical lift, low level cable drum
Opening height (H, mm)	H	H
Lintel height (h, mm)	$> H + 700$	$> H + 370$
Opening width (B, mm)	B	B
Height of the vertical tracks (A, mm)	$2H + 250$	$2H + 250$
The height of the shaft and cable drum (Ab, mm)	$A + 166$	
The working space of the door between the vertical tracks (A1, mm)	H	$H + 850$
Minimum side space (S, mm)	120	500
Location of the operator on the shaft(Q, mm)	240	≥ 650



Fitzpatrick S.A.L.

Fitzpatrick S.A.L.
PERFORMANCE METAL DOORSETS

Ain Saadeh industrial city
Beirut - Lebanon - PO. BOX 90-1101
Tel.: +961 1 901888 - Fax: +961 1 901333
email: firedoors@fitzpatricksal.com
www.fitzpatricksal.com